

Technical Data Sheet

SN1

Technology Description- Floating, electric powered, circulation and Trihalomethane (THM) removal equipment for potable water tanks and reservoirs. Designed for continuous operation and placement through 18-inch diameter (46 cm), minimum clear roof opening.

Materials of Construction - T316 stainless steel, thermoplastic rubber, High Density Polyethylene construction. GridBee® Machines are constructed using safe materials for contact with potable water. See certifications section below.

Spray Unit Direct Flow Rate - 75,000 Gallons Per Day, GPD. *Ixom application engineering evaluations often require sizing systems based on site specific conditions and NOT the spray aeration direct flow rate.*

Minimum Access Opening - Machine can be placed through 18 inch (46 cm) diameter opening.

Minimum Water Depth - Minimum of 48 inch (1.2 m) operating depth required, do not operate out of water.

Minimum Head Space - Minimum of 19 inch (50 cm) head space between water level and reservoir/tank ceiling required.

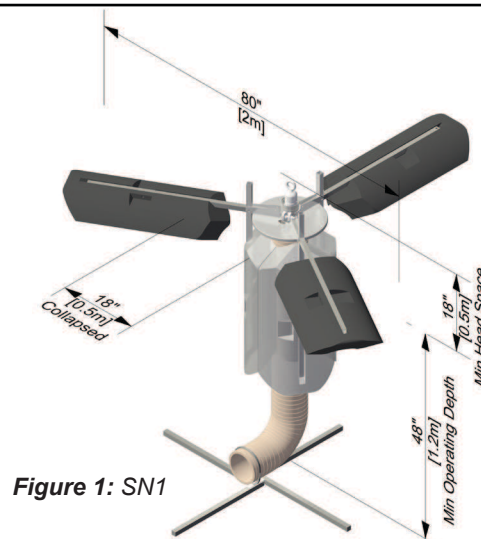

Figure 1: SN1

Intake - 20 to 100+ feet (6 to 30+ m) available in 6 inch (15.3 cm) diameter X 20 feet (6 m) sections, thermoplastic rubber, NSF/ANSI 61 approved. Includes low elevation inlet that draws water in a horizontal layer within 6 inches (15 cm) of the tank or reservoir floor. Includes intake retrieval chain constructed of 316 stainless steel.

Electrical Requirements - Requires 230vAC, 1-PH, 60Hz power. Ixom recommends secondary disconnect to be located near equipment access hatch. Optional 1-phase control panel operates both SN1 Spray Unit and Blower. *All switches, breakers, emergency stop buttons, control panels and other controls shall be installed in accordance to all NEC, State, and local regulations. (Not supplied by Ixom.)*

SN1 Motor - 1.5HP stainless steel submersible, designed for continuous operation, low power requirement, direct drive, no gearbox and no lubrication schedule required. See certifications section below.

SN1 Wiring - 3-conductor, submersible power cable for submersible motor wiring terminated exterior at top of tank.

Sealed Penetration Fitting - T316 stainless steel tank fitting with a 3/4" NPT female connection. Not designed as a submersible penetration.

Blower Motor - 0.5HP TEFC motor, designed for continuous operation, low power requirement, direct drive, no gearbox and no lubrication schedule required.

Shipping Size / Weight

- **Crate** - 72 inch x 48 inch x 48 inch (1.85 m x 1.22 m x 1.22 m) / 400lbs (185 kg) *Exact weight and dimensions varies dependent on machine configuration.*

Certifications - Ixom's potable water products are certified to ANSI/NSF Standard 61, and 372 for lead-free content. Learn more at: www.ixomwatercare.com/std61

Maintenance / Warranty - Limited maintenance. Limited 2-year parts and labor warranty. See Warranty Statement for details.