

**GS-9**

**Technology Description-** GridBee® electric submersible water circulation equipment, designed for continuous operation. Constructed with T316 stainless steel shell and safe materials for contact with potable drinking water. Designed to be placed into service through roof hatch without tank entry.

**Materials of Construction** - T316 stainless steel shell and hardware construction. UHMW-PE end plates for worry-free safe contact with all tank surfaces. See certifications section below.

75 ft (22 m) or 150 ft (44 m) of T316 stainless steel retrieval chain included for machine installation and retrieval without requiring tank entry.

**Minimum Access Opening** - Machine can be placed through 12 inch (30 cm) diameter opening.

**Minimum Water Depth** - The mixer requires at least 2 feet (0.6meters) of water above the discharge slots to prevent pump cavitation and motor damage. Shut the mixer off if water surface is less than 2ft from the mixer slots.

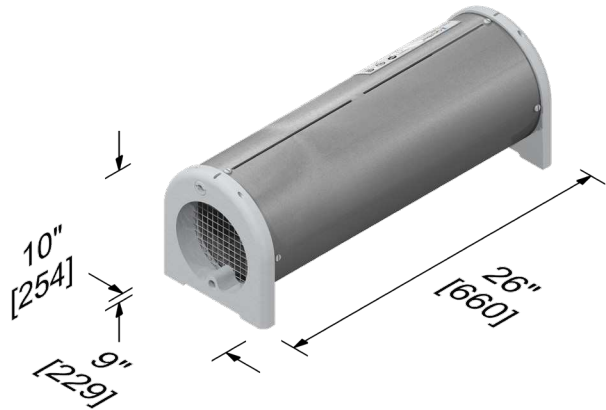

Figure 1: GS-9

**Intake** - Intake draws water in a horizontal layer within 2 inches (5.08 cm) of the tank or reservoir floor. Chlorine boost connection point on machine via 3/8" NPT female thread for adapting to 1/2" (13mm) hose for fast chlorine dispersion during in-reservoir boosting.

**Electrical Requirements** - 120VAC motor requires 120VAC/1PH power source outlet (**minimum 20 Amp service**). The GS-9 draws approximately 9.0 Amps @ 120VAC / 60Hz. Nominal power consumption of 800 Watts.

**Motor** - 1/2 HP stainless steel submersible, designed for continuous operation, low power requirement, direct drive, no gearbox and no lubrication schedule required. Automatic reset, on-winding thermal overload protection and surge arresters built in. Mounted in flow sleeve for superior cooling and long motor life in submerged temperatures up to 122 F. See certifications section below. 120VAC/1PH standard, other voltages available as special order.

**Wiring** - Includes either 75 ft (22 m) or 150 ft (44m) of 10AWG submersible power cable to terminate within junction box at top of tank. Junction box included.

**Sealed Penetration Fitting** - T316 stainless steel tank fitting and cord grip included for sealed cord entry through tank roof. Not designed as a submersible penetration.

**Optional Accessories** - (1) Portable Chlorine Boost Hose and Boost Pump System, (2) Dual Injection Kit, (3) Control and SCADA Panel

**Shipping Size / Weight**

- 75 ft unit** - Box 1 of 2: 44x16x12 in. / 88 lbs, Box 2: of 2: 17x13x8 in. / 25 lbs: Total shipment weight: 123 lbs
- 150 ft unit** - Box 1 of 2: 44x16x12 in. / 127 lbs, Box 2: of 2: 17x13x8 in. / 41 lbs: Total shipment weight: 168 lbs

**Certifications** - Ixom's potable water products are certified to ANSI/NSF Standard 61 and 372 for lead-free content. Learn more at: [www.medoraco.com/std61](http://www.medoraco.com/std61)

**Maintenance / Warranty** - Limited maintenance. Limited 5-year parts and labor warranty, See Warranty Statement for details.